

ETP

Electronic transmitter
for pressure and level

ETP90 Digital transmitter

for gauge pressure, absolute pressure,
differential pressure and level



ETP90 has, among others, the following advantages:

- ETP90 is designed with microprocessor based electronics.
- Configuration can be performed direct on the transmitter with buttons, standard Hart handterminal, or the PC program DOX9 (ETP90H).
- The transmitter is directly connected to the process media without any need for pressure intermedia, this eliminates temperature drift and gives a rugged design.
- A large number of process connections gives freedom of choice for most applications.
- Withstands media temperatures up to 150 °C continuously, for higher temperatures, most connections can be delivered as remote seals.
- Approved for EExia, 3A and CE (EMC and PED).
- Stainless steel IP67-housing protects from dust and moisture.
- Durable against media with solid particles.
- Hygienic design without dirt collecting corners, easy to clean.

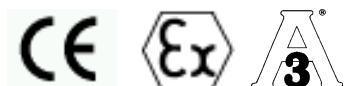

Function:

ETP90 is a transmitter series with a wide amount of process connections to fit most applications. The transmitter can measure liquids, gases and steam.

ETP90 is durable against overload. For most pressure ranges the transmitter can be overloaded at least three times the highest pressure range value, and for short pressure surges even more.

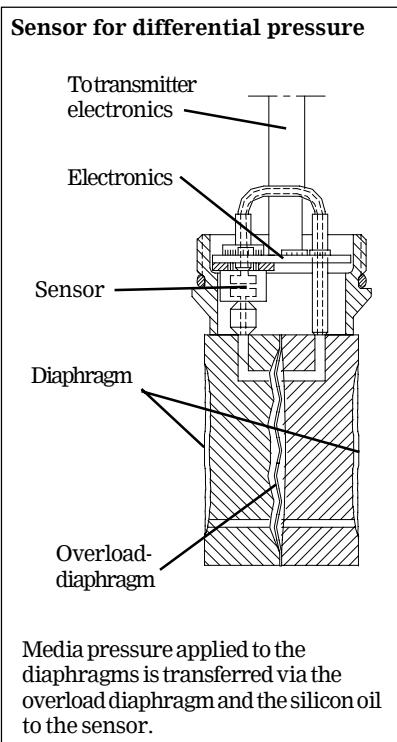
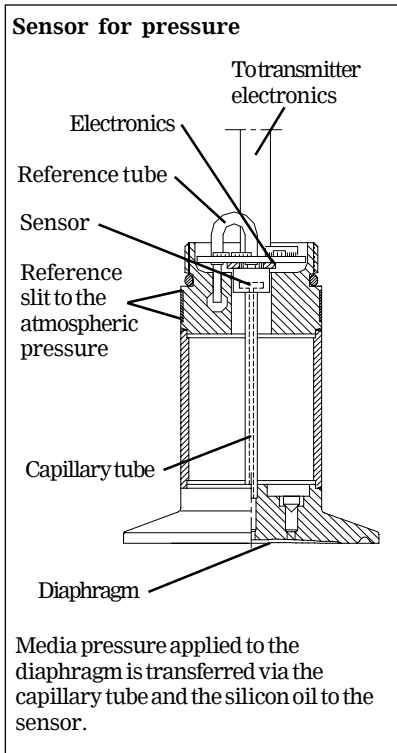

ETP90 is directly connected to the media without the need for pressure intermedia. This eliminates the problems usually associated with pressure intermedia, such as temperature drift. Since ETP90 does not use pressure intermedia temperature influence is very low. ETP90 is both temperature- and longterm stable.

ETP90A is designed for two wire connection 4–20 mA.

ETP90H has also HART communication.

ETP90PA has Profibus PA communication and ETP90FF Foundation Fieldbus.

Transmitter for Pressure and Level

ETP90 uses a piezo-resistive pressure sensor which is connected to the pressure of the media via a capillary tube and a diaphragm. Media pressure applied to the diaphragm is transferred via silicon oil to the pressure sensor. The oil completely fills the cavity in the sensor, the capillary tube and the cavity above the diaphragm. This means that the diaphragm movement is very small at pressure changes. The capillary tube protects the pressure sensor from transient pressure surges.

To ensure that the sensor has the correct reference pressure, the rear side is connected to ambient atmospheric pressure via a tube, designed in order that air passes "cold surfaces" closest to the pressure connection of the transmitter. Any humidity in the air will condense on these surfaces. The condensate flows out and the remaining air in the tube stays dry. Additionally, the reference pressure connection is designed to prevent flushing water from entering.

ETP90A has microcomputer-based electronics, which communicate with the outside world with a 4 to 20 mA signal and can be configured/calibrated by means of keys and switches in the connection space.

ETP90H has microcomputer-

based electronics, which communicate with the outside world with a 4 to 20 mA signal as well as HART communication.

The electronics measure and converts the output signal from the pressure dependent sensor bridge to digital values. Furthermore, the total resistance of the sensor bridge is measured and these values are converted to digital temperature values. The electronics perform compensation for temperature drift of the sensor by means of compensation values entered at the factory calibration and at the same time the temperature measurement is calibrated. Compensation for the non-linearity in the sensor is done in the same manner.

Different kinds of transfer functions, such as linear and square root can be selected. With ETP90H also curves, formulae etc, can be selected. The electronics perform the calculation for the selected transfer function and then the digital value is converted to analogue for the 4 to 20 mA current loop. The digital value can also be read via HART communication in optional engineering units, percentage or current. ETP90H can be configured/calibrated to a certain extent by means of keys and switches in the connection space and fully by means of a hand terminal or a PC via HART communication.

Transmitter for Differential Pressure

The transmitter has a central piezo-resistive sensor connected to the diaphragm chambers via two capillary tubes.

Each of the two process media pressures act on a separating diaphragm that have a small spring constant. An overload membrane with adapted spring constant is located between the two separating diaphragms. The diaphragm chambers and the sensor are filled with silicon oil. The pressure on both sides of the overload diaphragm is transferred

to the sensor by means of the silicon oil.

At a pressure difference between the two separating diaphragms within the measuring range of the transmitter, all three diaphragms will move freely. At overload exceeding the measuring range one of the separating diaphragms will however lay against the profiled surface while the overload diaphragm still can move freely. The differential pressure across the sensor can in that way not increase further even if the differential pressure across the separating diaphragms increases. This protects the sensor against overload and transient pressure surges.

The electronics perform compensation for temperature drift of the sensor by means of compensation values entered at factory calibration, and at the same time the temperature measurement is also calibrated. Compensation for the non-linearity in the sensor is done in the same manner.

Different kinds of transfer functions, such as linear and square root can be selected. With ETP90H also curves, formulae etc, can be selected. The electronics perform the calculation for the selected transfer function and then the digital value is converted to analogue for the 4 to 20 mA current loop. The digital value can also be read via HART communication in optional engineering units, percentage or current. ETP90H can be configured/calibrated to a certain extent by

means of keys and switches in the connection space and fully by means of a hand terminal or a PC via HART communication.

DOX9

DOX9 is a software tool for configuration, calibration and documentation of ETP90. DOX9 is delivered on a CD-ROM for Windows 95/98/2000 and Windows NT.

DOX9 contains a database with available transmitter types and can be used for configuring transmitter specific parameters and for performing maintenance- and output-calibration and also "autozero". DOX9 can also be used for copying configurations, backup on harddrives, sending/ receiving via standard HART-communication and selftest with alarmfunction.

DOX9 also contains onlinehelp, data sheets and operating instructions.

Handterminal

For configuring of ETP90H a handterminal of HART-type can be used.

Transmitters with fieldbus communication

ETP90 can also be delivered with Profibus PA or Foundation Fieldbus communication (FF will be released 2005).

The electrical connection and communication protocol for both PA and FF follows the standard IEC 1158.

ETP90PA and FF can be configured through the fieldbus communication or with buttons

and a rotary switch direct on the transmitter.

Display

ETP90 can, as an option, be equipped with a digital display. The display is connected in series with the 4-20 mA output. The display can be programmed to show the pressure in any unit.

ETP90PA and ETP90FF can be equipped with a digital display (factory mounted). The display can show the output in the chosen unit. The display can also be used when configuring the transmitter with the buttons and the rotary switch.

The display is mounted under the transmitters cap. The cap is then exchanged to one with a display window.

Approvals

ETP90 with process connections 7, 8, 9, A, D, E and V are approved for 3A.

ETP90H/PA/FF are approved for use in explosion proof areas, EExia IIC T4, according to the ATEX directive by NEMKO.

ETP90 is CE marked according to the directives for EMC and the directive for pressure equipment, PED.

All types are filled with an FDA approved silicon oil.

Lightning protection

ETP90 can be equipped with an integrated lightning protection that withstands high overvoltage surges.

Ordering codes.

See table on next page for code description and possible combinations

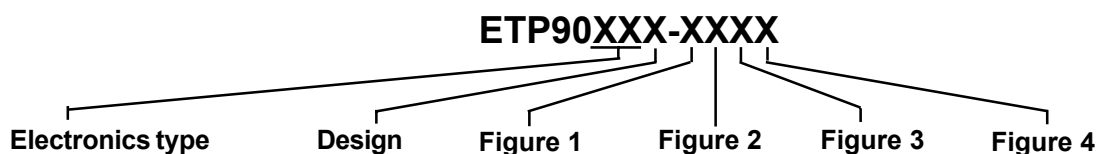

Ordering example:

Threaded transmitter with R1/2" external thread, and HART electronics, measuring range 0-65 kPa gauge pressure, will get the order code **ETP90H-4140** with calibrated range 0-65 kPa

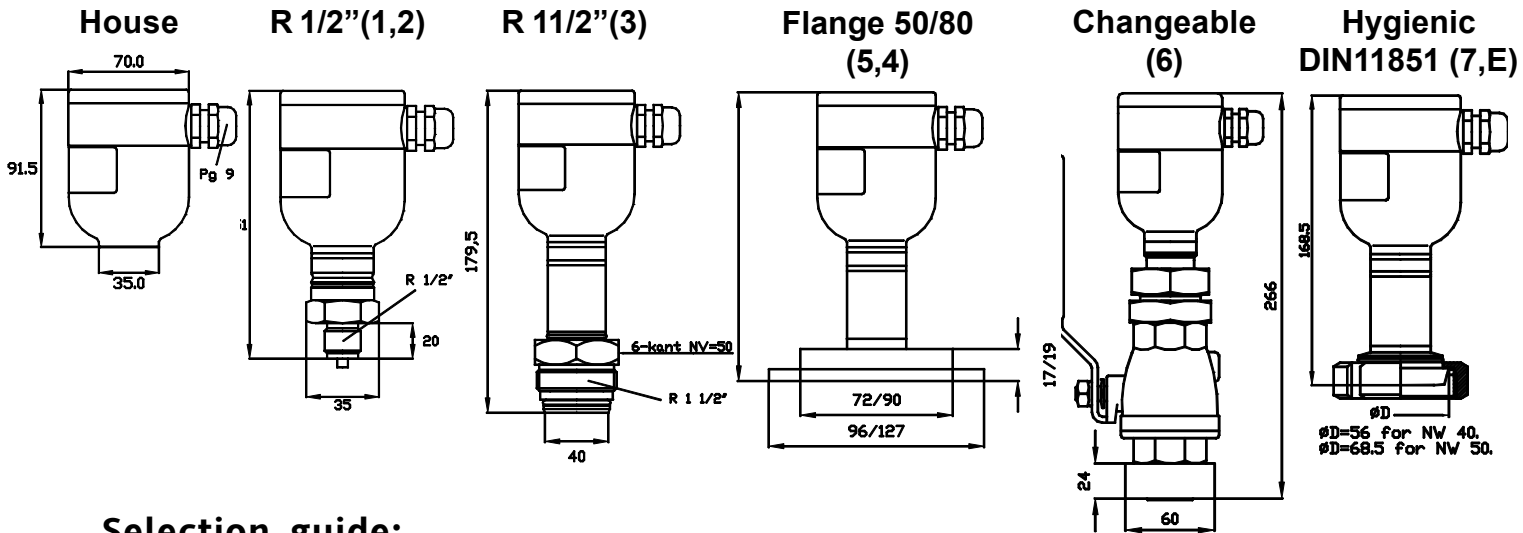

Selection guide:

Process connection	Electronics	Design	Figure 1	Figure 3	Figure 4	R1/2'' External	NPT1/2'' External	R1 1/2'' External	Flange 80/3''	Flange 50/2''	Changeable	Hygienic DIN11851/40
Figure 2						1	2	3	4	5	6	7
Electronics												
Analogue	A					X	X	X	X	X	X	X
HART electronics	H					X	X	X	X	X	X	X
Profibus PA	PA					X	X	X	X	X	X	X
Foundation Fieldbus*1	FF					X	X	X	X	X	X	X
Design												
Intrinsically safe *3		E				X	X	X	X	X	X	X
Lightning protected		L				X	X	X	X	X	X	X
Diaphragm												
None, only connection N			0					X	X	X	X	X
Stainless steel 1.4462/1.4435			3			X	X	X	X	X	X	
Hastelloy C 276			4			X	X	X	X	X	X	X
Tantalum			5					X	X	X	X	
Span min/max												
0,24 - 7 kPa				1		X	X		X	X		X
1,2 - 35 kPa				2		X	X	X	X	X	X	X
6,7 - 200 kPa				4		X	X	X	X	X	X	X
0,067 - 2 MPa				6		X	X	X	X	X	X	X
0,14 - 4 MPa				7				X	X	X		
0,27 - 8 MPa				7								
0,5 - 15 MPa				8		X	X					
Measuring principle												
Gauge pressure/Diff.pressure					0	X	X	X	X	X	X	X
Absolute pressure					2	X	X	X	X	X	X	X

*1 Release 2005

*2 No drawing. For dimensions please contact Customer Center.

*3 Not for electronics A.

Transmitter types, description:

Threaded transmitter R 1/2" and NPT 1/2". (1 and 2)

The threaded transmitter with connection to R 1/2" thread is intended for clean media. At a media temperature higher than 90°C, a cooling pipe is used to prevent too high temperature at the sensor.

The threaded connection is normally sufficient to keep the transmitter in place. At specific conditions or wall installation the transmitter can be supported and reinforced with an installation kit.

Threaded transmitter with extended diaphragm, R1 1/2". (3)

This transmitter connection with a connection to a 1 1/2" thread is intended for fibre-rich and viscous media. The extended front diaphragm is in connection with the media without any pocket inside the tank or pipe.

An optional adapter is available for connection to a 2" thread and an optional welding sleeve for R1 1/2". There are no additional requirements on the installation. The transmitter may also be connected inside a threaded R1 1/2" cylinder, such as a pipe sleeve or shut-off valve.

Flange connected transmitter. Flange 80 mm/3", Flange 50 mm/2" and DRD flange. (4, 5 and D)

A flange connected transmitter is intended for level measurement in open tanks with liquid media, even with fibre rich and/or viscous media. The risk of blockage is eliminated by the large area of the exposed diaphragm.

The transmitter is clamped between standard flange rings. The transmitter fits slip-on flanges of ANSI or DIN type (for flange 50 the centrum hole is increased to fit the transmitter). The type of flange has to be stated at the time of order. (See Accessories). Transmitters with flange 50 mm/2" and six holes, for use with MWP10 is supplied upon request.

Hygienic clamp connected transmitter.

Clamp38, Clamp51 and Varivent. (9, A and V)

A clamp connected transmitter is used when special hygiene requirements are needed, such as those in the pharmaceutical industry. The design meets ISO 2852 and the transmitter is easy to install and remove.

If clamp 38 connection is not available, the optional connector piece, clamping ring and gasket ring may be used. Connection details for clamp 51 and Varivent is available upon request but not available from stock.

Hygienic screw connected transmitter.

DIN11851/40 mm, SMS Rd60-6, DIN11851/50 mm. (7, 8, C, E)

A screw connected transmitter giving a hygienic connection, for example, used in the Dairy industry. The exposed diaphragm has direct contact with the media which makes it possible for the transmitter to measure even viscous liquid media, without becoming silted up.

The transmitter is installed in accordance with the Rd 60-6 connection of SMS 1146, DIN 405 and DIN 11851. The transmitter is screwed to the connector.

Transmitter removable during operation. (6)

This transmitter type is intended for liquid media, even with viscous or fibre-rich media. The extended diaphragm is in connection with the media without any pocket inside the tank or pipe.

The transmitter can be removed during operation and comprises three parts; the transmitter, a ball valve and a welded casing/compression flange. This compression flange is designed to fit an ANSI or DIN 80 mm/3" flange and may be installed to measure levels according to the hydrostatic principle.

Differential pressure transmitter. (G, H and T)

Differential pressure transmitters is used to measure the difference between two pressures. The transmitter types G and H can withstand high static pressures, both one- and double-sided, (up to 15 MPa). The connection type G has threaded connection and type H has one side threaded and the other side with flange 80 mm.

They are used for level measurements in pressure vessels and flow measurements of gases, liquids and vapour. Other application areas are differential pressure measurements across filters or heat exchangers, and pressure measurements with narrow measurement ranges where there is a danger of high one-sided pressure overload.

The differential pressure transmitter type T can be delivered with two process connections 3-9, A, C, D, E och V. One side is directly connected to the transmitter and the other side with a capillary tube (normal length of the capillary tube is 2000 mm, other length upon request). *(Type T: Highest static pressure is the same as the overload for the pressure range. Same exceptions as for the selected process connection.)*

Transmitter with capillary tube. (N)

This transmitter type is designed with the connection (with the measuring diaphragm) separated from the transmitter housing. The media pressure is transferred via a capillary tube (normal length of the capillary tube is 1000 mm, other lengths upon request) to the sensor located in the transmitter housing. This type can be delivered with process connections 3-9, A, C, D, E and V. The transmitter type is designed for applications with high vibration levels or high media temperatures. Withstands extremely high media temperatures.

Technical data ETP90 [A in square brackets]*4

Type:	Electronic pressure transmitter with microcomputer based electronics.	External series resistance:	R kohm = (Supply voltage -11)/20. For HART communication min. 250 ohm.
Function:	Directly connected transmitter with no pressure intermedium. Piezo resistive sensor with capillary tube.	Series resistance dependant:	Less than +/- 0,1%
Operating range:	From absolute zero to 100% of maximum prssure range value.	Supply voltage dependant:	Less than 0,1 %
Measuring span:	Adjustable from the maximum pressure range and 1/30 of this .	Temperature tolerance:	Less than +/- 0,1% [0,25%] of max. span. (In the range -10 to +70 degrees C.)
Zero point:	Adjustable from -100% to 100% of the maximun pressure range value	Working pressure influence: *1	Max 0,06% per MPa at max measuring range, 200 kPa and 1 MPa. Max 0,2% per MPa at max measuring range, 7/35 kPa.
Working pressure: *1	Max 15 MPa (static pressure)	Long time stability:	Less than 0,08 % per year.
Overload ^{3:}	7 kPa: Max 100 kPa	Vibration tolerance:	
	35 kPa: Max 250 kPa	Perpendicular to diaphragm:	Max +0,3 kPa/G
	200 kPa: Max 600 kPa	Parallel to diaphragm:	Max +0,02 kPa/G
	2 MPa: Max 6 MPa	Vibration test:	Meets tests according to. IEC770 and DNV class B
	4/8/15 MPa: Max 30 MPa	Repeatability:	Less than +/- 0,1 % of measuring range.
Material:	Diaphragm: Stainless Steel/Hastelloy/Tantal (special coatings on request)	Accuracy:	Less than +/- 0,1 % of max. span (includes linearity, hysteresis and repeatability). *2
	Other wet parts: SS2343/SS2353	Installation:	Direct on process connection.
	Housing: PPS plastics/SS2333	Electrical connection:	Internal terminal block.
Ambient temperature:	-20 to +80 degrees C	Max wire area:	2,5 mm ²
Time constant:	Interchangeable between 0,1-10 s As delivered 0,1s.	Cable entry:	For round cable 5-12 mm.
Mediatemperature:	150 degrees C *5	Protection class:	IP67
Output:	4-20 mA, two wire connection, the signal proportional to pressure. Max. current at overload 22,5 mA . HART , Profibus PA or FF communication.	Electrical safety:	Meets the EN60204-1
Supply voltage::	11-55 V DC	Electrical interference:	Meets the EN50081-2 and EN50082-2
Filling liquid:	AK100, food and drug-approved silicon oil (FDA approval)	Intrinsic safety (ATEX):	EExia IIC T4 (Nemko) [not for ETP90A]
Weight:	700-1500 g depending on processconnection	PED:	According to 97/23/EG

For ETP90 with Profibus PA and Foundation Fieldbus some data differs, contact ABB for information

*1 Only for differential pressure transmitter.

*2 Accuracy 0,05% upon request.

*3 Max sensor overload. Different process connections have other limitations.

*4 For Profibus PA and Foundation Fieldbus some data differs.

*5 Short time up to 200 degrees C. Some types can be delivered for up to 275 degrees C.

For further information, installing and commissioning instructions, drawings, accesories, etc refere to the ETP90 Manual (contact Customer Center).

ABB Automation Technologies AB
Instrumentation, S-191 85 Sollentuna
Customer center+46 20-32 22 22

Internet: www.abb.se
E-mail: instrumentation@se.abb.com